

RoHS Compliant

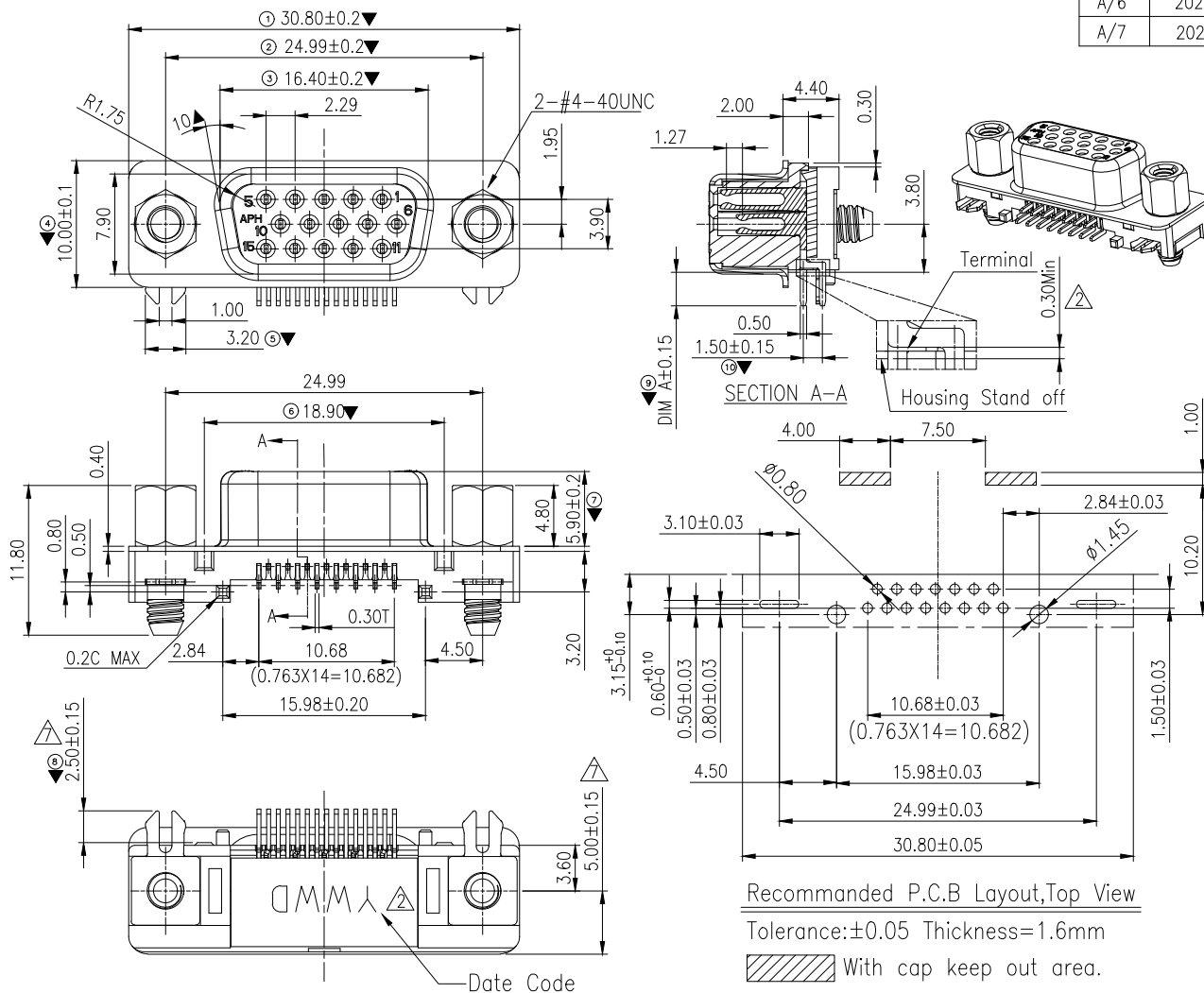

REV.	ECN NO	LTR	DESCRIPTION	REVISER	DATE
A/4		△	螺丝材质修改为BRASS H62	Geng	2019/12/12
A/5		△	增加重点符号	Geng	2020/08/06
A/6	20201215001	△	统一DATA CODE:30815FB3BD8HF切换为YWWD	Allen_Tsai	2020/08/06
A/7	20230414001	△	Rivet材质修改为BRASS, C3604;DIM2.50&5.00±0.15	LIYIJE	2023/04/14

NOTE: 1.MATERIAL:  
Housing: High temperature plastic, PA9T(GP2450NH)+30%G.F (UL94V-0)  
Cover: High temperature plastic, PA9T(GP2450NH)+30%G.F (UL94V-0)  
Cap: High temperature plastic, LCP(E130I)+30%G.F (UL94V-0)  
COLOR:BLACK  
Terminal: PHOSPHOR BRONZE C5191H ,T=0.30mm  
Shell: SPCC ,T=0.40mm  
Fork: SPCC ,T=0.40mm  
Rivet: Brass C3604  
Screw: BRASS H62  
2.Finish:  
Terminal:  
Contact area: selective gold plated, see P/N information.  
Soldering tails: matte Tin plating 100u" thickness Min.  
Under plating: nickel plating 50u" thickness Min. overall.  
Fork:  
Matte Tin plating 100u" thickness Min.  
Under plating: Nickel plating 50u" thickness Min. overall.  
Shell:Nickel plating 50u" thickness Min. overall.  
Rivet:Nickel plating 50u" thickness Min. overall.  
Screw:Nickel plating 50u" thickness Min. overall.  
3.Packing is per AMTA packing specification hazardous.  
4.This product doesn't contain environmental hazardous per directive2011/65/EC for RoHS compliant  
5. Screw Twist Force: 3.0Kgf.cm Min. △  
Screw Recede Force: 1.5Kgf.cm Min. △  
6. Salt spray : 48H

7.THE DIMENSIONS WITH "▼" MARK ARE CRITICAL AND SHOULD BE CONTROLLED BY QC.  
PART NUMBER INFORMATION  
30815F-B-X-X-XX-HF  
HOUSING COLOR:  B: BLUE(661C)  HF: Halogen Free  
DIM A OPTION

CONTACT PLATING:

- 1: Gold flash
- 3: Gold 10u"
- 5: Gold 15u"
- 6: Gold 30u"

B:Rivet Without Screw  
C:Rivet With Screw

DATE CODE INFORMATION:

Y WW D  
DAY(1~7)  
Week(01~52)  
YEAR(0~9)

P/N	Dim A	
D4	2.00	With CAP
D5	2.65	
D6	3.00	
D7	2.00	Without CAP
D8	2.65	
D9	3.00	

图号 (DWG NO)	G-308-S1-22	单位 (UNIT):	MM		<b>显赫电子科技有限公司</b> XianHe Electronic Technology co., Ltd.
类别 (DWG TYPE)	SALES DWG	比例 (SCALE)	1:1		
版次 (REV):	A/7	页次 (PAGE):	1/1	TEL:0769-89138899 FAX:0769-89100950	
设计 (DESIGN)	JOY	未注公差 TOLERANCE UNSPECIFIED		品名 (ITEM NO)	D-SUB 15Pin 母 Slim, 2.0 CH=3.80mm
审核 (CHECKED)		X.X ± 0.30 X.XX ± 0.20 X.XXX ± 0.10 X ± 2' X.X ± 1'		料号 (PART NO)	30815F-B-X-X-XX-HF
核准 (APPROVED)					